

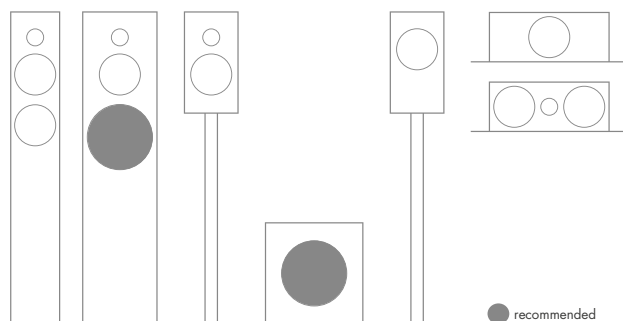

# SYMPHONY II

## 8-412/C8/32 HEX

#1.2100.07

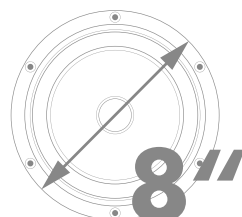
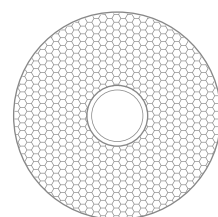

### Technische Daten Technical data

Nennimpedanz Nominal impedance	$Z_n$	8	$\Omega$
Gleichstromwiderstand DC resistance	$R_e$	7.0	$\Omega$
Resonanzfrequenz 1W Resonance frequency 1W	$f_r$	25	Hz
Resonanzfrequenz TSP Resonance frequency TSP	$f_r$	28	Hz
Nachgiebigkeit der Aufhängung Suspension compliance	$C_{MS}$	1.46	mm/N
Mechanische Güte Mechanical Q	$Q_{ms}$	5.54	
Elektrische Güte Electrical Q	$Q_{es}$	0.43	
Gesamtgüte Total Q	$Q_{ts}$	0.40	
Mechanischer Widerstand Mechanical resistance	$R_{MS}$	0.88	kg/s

Gesamte bewegte Masse (einschl. bewegter Luftmasse) Total moving mass (incl. air mass)	$M_{MD}$	29.6	g
Effektive Abstrahlfläche Effective piston area	$S_D$	222	cm <sup>2</sup>
Induktivität Schwingspule Voice coil inductance	$L_e$	0.72	mH
Kraftfaktor Force factor	$B_{xl}$	8.0	Tm
Xmax elektrisch Xmax electrical	+/-	5.5	mm
Xmax mechanisch Xmax mechanical	+/-	14.2	mm
Äquivalentvolumen Equivalent volume	$V_{AS}$	101.0	dm <sup>3</sup>
Mittlerer Kennschalldruckpegel 1W/1m Characteristic SPL 1W/1m		89	dB SPL
Belastbarkeit Rated power		80*	W

\* IEC 60268-5

### Mechanische Daten Mechanical data

Gesamtdurchmesser Overall diameter	223	mm
Einbaudurchmesser Cutout diameter	190	mm
Korbrandstärke Frame depth	7.8	mm
Gesamtiefe Overall depth	108.3	mm
Durchmesser Schraubloch Screw holes diameter	5.3/9	mm
Terminal Terminal	2.8/4.8	mm
Gewicht Weight	2.13	kg

### Magnet Magnet

Magnetische Flussdichte Flux density	1.00	T
Höhe Luftspalt Height of air gap	8	mm
Material Material	Ferrite	
Dimensionen Dimensions	102 x 46	mm
Höhe Height	22	mm
Antriebssystem Motor type	Overhung	
Ferrofluid Ferrofluid	no	

### Frequenzbereich Frequency range

Empfohlener Frequenzbereich Recommended frequency range	40 – 2000 Hz
--	--------------

### Frequenzgang Frequency response

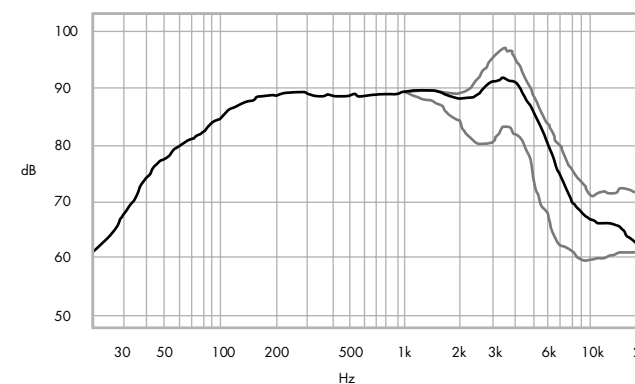

SPL 2,83 V/1m; black 30°, grey 0°, 60°; half space; endless baffle; enclosure 700 l

### Schwingspule Voice coil

Diameter Durchmesser	32	mm
Höhe Height	19	mm
Drahtmaterial Wire material	CCA W	
Trägermaterial Former material	Kapton	
Wicklungslagen Layers	1	

### Technische Abmessungen Technical dimensions

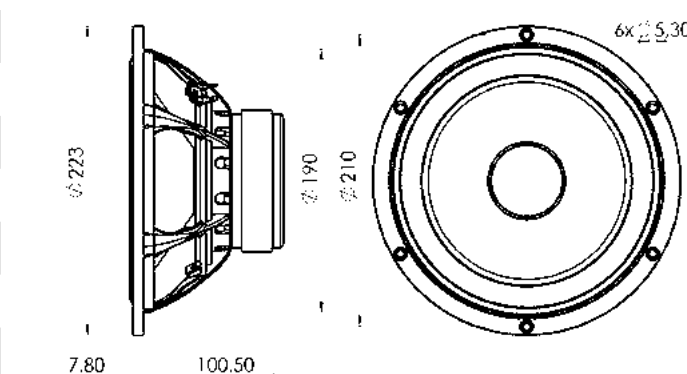

### Impedanz Impedance

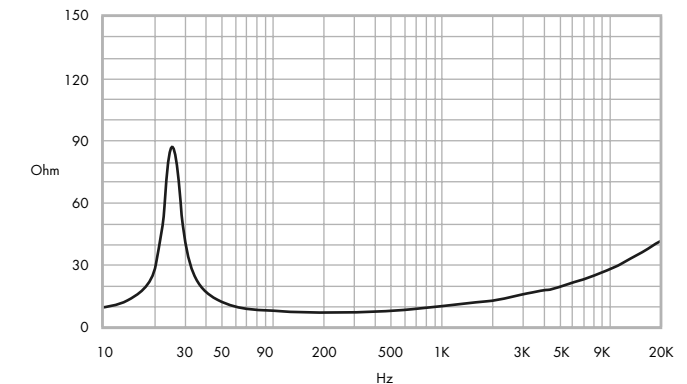

Measured free air without baffle